

GENERAL SPECIFICATIONS	
IGNITION TYPE	WASTED SPARK
MAX. INPUT RPM	3500 RPM
OPERATING TEMPERATURE RANGE	-38°C TO +107°C
VOLTAGE INPUT RANGE	8.5 - 30 V _{DC}
OPERATING POWER REQUIREMENTS @ 2700 RPM	0.70±0.2 A @ 14 V _{DC} 0.35±0.2 A @ 28 V _{DC}
MANIFOLD PRESSURE INPUT RANGE	5 - 45 inHg
TIMING ACCURACY	±2°
BUILD	surefly_4_20082201_seed_3067.pof
CHECKSUM	005967A2

REVISIONS				
ZONE	REV.	DESCRIPTION	DATE	APPROVED
ALL	PT-1	PROTOTYPE 1	04/14/2017	RVC
ALL	PT-2	PROTOTYPE 2	06/01/2017	RVC
ALL	IR	INITIAL RELEASE FOR PRODUCTION	05/21/2018	RVC
ALL	A	ECO 19-001	03/25/2019	RVC
ALL	B	ECO 20-001	03/30/2020	RVC
ALL	C	ECO 20-002	01/11/2021	RVC
ALL	D	ECO 21-004	03/01/2021	RVC
ALL	E	ECO 22-001	01/20/2022	RVC
ALL	F	ECO 22-002	04/01/2022	RVC
ALL	H	ECO 24-001	08/01/2024	RVC

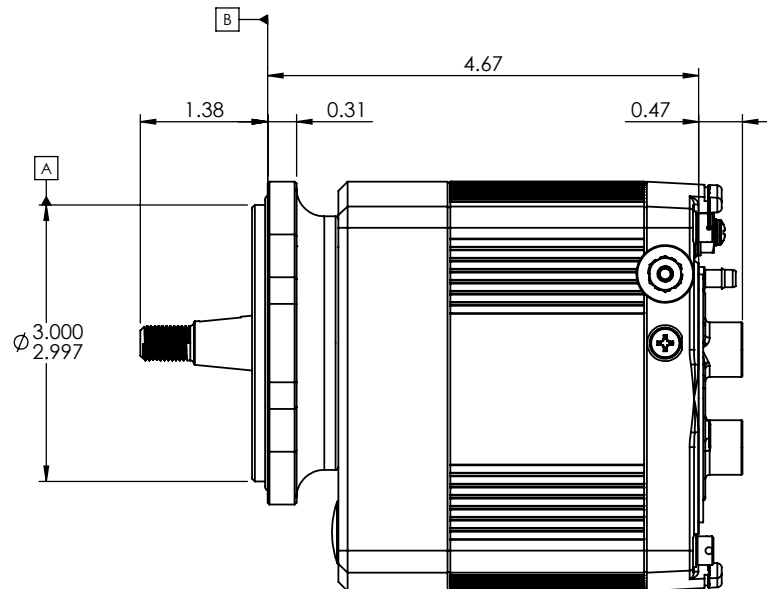

DIP SWITCH SETTINGS							
ENGINE TIMING	TIMING OPTION	DIP SWITCH				LED CODE	TIMING SCHEDULE
		1	2	3	4		
30°	VARIABLE	OFF	ON	ON	ON	----	A-30
	FIXED	ON	ON	ON	ON	----	F-30
28°	VARIABLE	OFF	ON	ON	OFF	----	A-28
	FIXED	ON	ON	ON	OFF	----	F-28
26°	VARIABLE	OFF	ON	OFF	ON	----	A-26
	FIXED	ON	ON	OFF	ON	----	F-26
25°	VARIABLE	OFF	ON	OFF	OFF	----	A-25
	FIXED	ON	ON	OFF	OFF	----	F-25
24°	VARIABLE	OFF	OFF	ON	ON	----	A-24
	FIXED	ON	OFF	ON	ON	----	F-24
22°	VARIABLE	OFF	OFF	ON	OFF	----	A-22
	FIXED	ON	OFF	ON	OFF	----	F-22
20°	VARIABLE	OFF	OFF	OFF	ON	----	A-20
	FIXED	ON	OFF	OFF	ON	----	F-20
18°	VARIABLE	OFF	OFF	OFF	OFF	----	A-18
	FIXED	ON	OFF	OFF	OFF	----	F-18

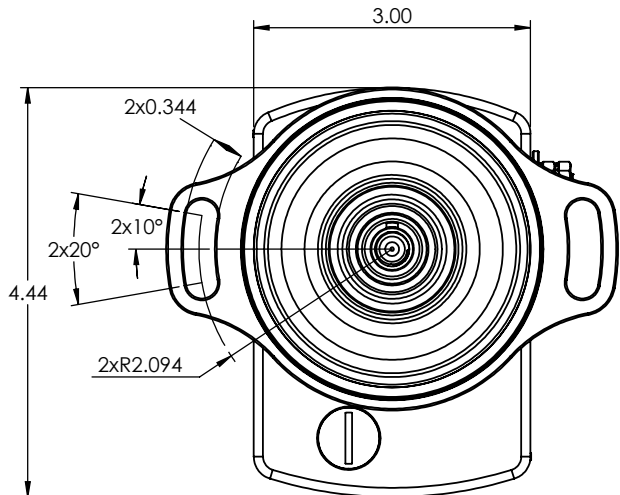
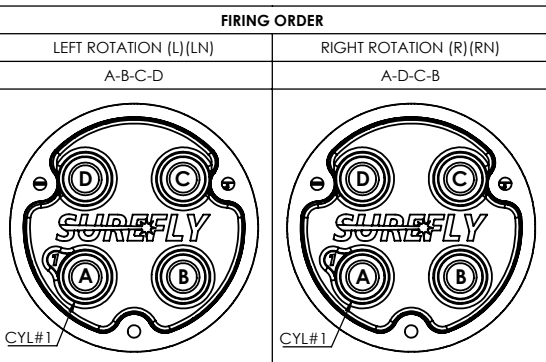

SureFly
Granbury, Texas

4 CYLINDER NON-IMPULSE COUPLER IGNITION

SCALE:	MATERIAL:	FINISH:
1:2	N/A	N/A
DIMENSIONS IN INCHES UNLESS OTHERWISE SPECIFIED		DATE:
TOLERANCES:		DRAWN BY:
ANGLES	0.X	0.XX
±1°	±0.050	±0.030
	±0.010	±0.001
SHEET:		PART NO:
1/1		SIM4N
DRAWN BY:		REV:
R. CONDY		H
DATE:		
05/21/2018		